

**Basic Instructions only!**  
For more detailed product information, refer to the  
teacherTAXI Owner's Manual 204A099.

**⚠ CAUTION**

*Make sure anyone assembling, installing or using these products has read and understands these instructions.*

**⚠ CAUTION**

*Failure to comply with Warnings and Cautions in this document or on the equipment can result in damage to property or injury.*

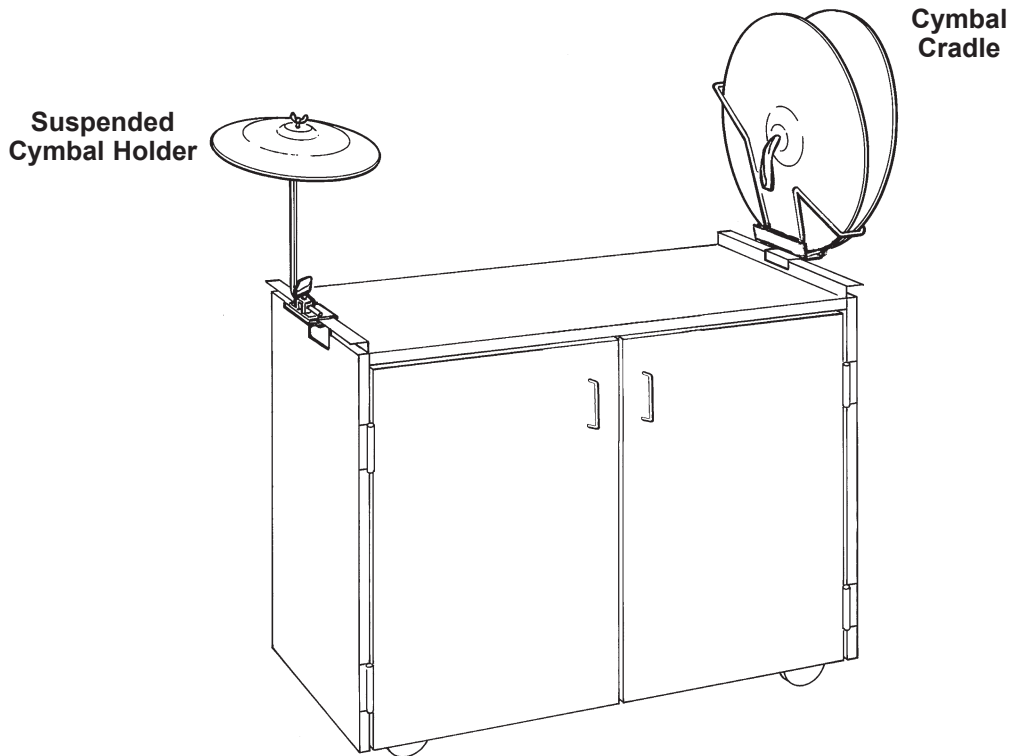

### Contents

Supplied Hardware - Suspended Cymbal Holder . . . . .	2	Suspended Cymbal Holder Assembly . . . . .	3
Parts List - Suspended Cymbal Holder . . . . .	2	Cymbal Cradle Assembly . . . . .	4
Supplied Hardware - Cymbal Cradle . . . . .	2		
Parts List - Cymbal Cradle . . . . .	2		



Visit the Percussion Workstation web page at [wengercorp.com](http://wengercorp.com) for more information.

**Note:** Please read and understand these instructions before proceeding.  
**Note:** If you need additional information, contact Wenger Corporation using the information below.

## Supplied Hardware - Suspended Cymbal Holder



## Parts List - Suspended Cymbal Holder

Item	Description
1	Upper Bracket Assembly
2	Lower Plate
3	3/8" ID Washer
4	5/16-18 Wing Nut
5	Rod Assembly (includes fasteners)

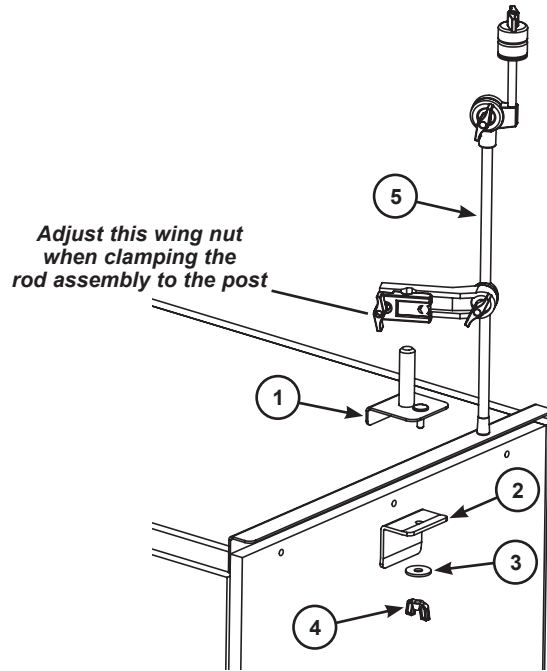

## Supplied Hardware - Cymbal Cradle

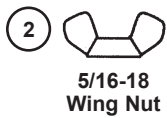

## Parts List - Cymbal Cradle

Item	Description
1	Lower Plate
2	5/16-18 Wing Nut
3	Upper Bracket
4	Cymbal Cradle

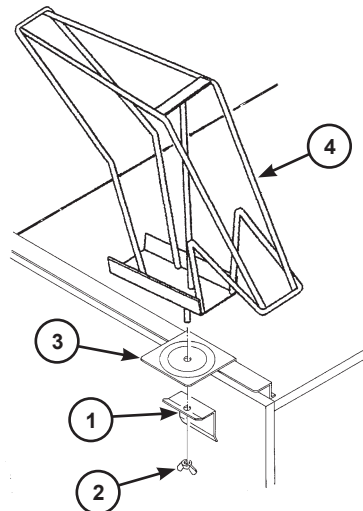

# ***Suspended Cymbal Holder Assembly***

1. Set the upper bracket on the percussion cabinet rail.
2. Loosely assemble the lower plate to the upper bracket, using a washer and a 5/16-18 wing nut.

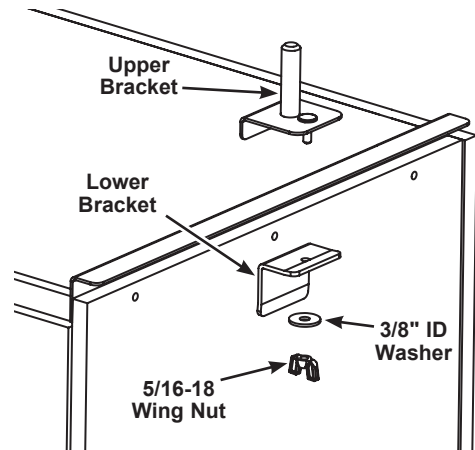

4. Assemble the rod assembly to the post of the upper bracket assembly as shown by adjusting the wing nut.

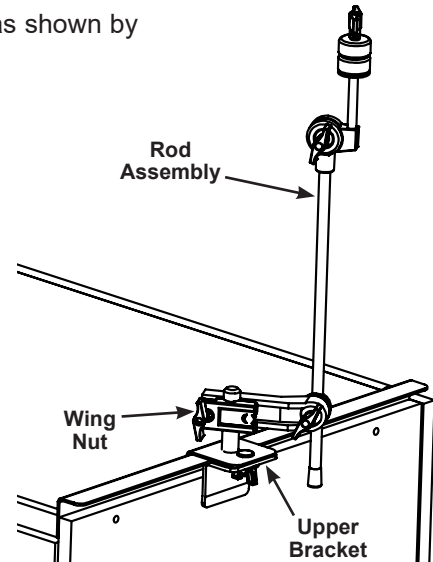

5. Remove the upper wing nut and nylon spacer. Install the cymbal, and secure with the spacer and a wing nut.
6. Move the upper bracket along the rail until the cymbal is in a convenient position, then lock securely with a lower wing nut.

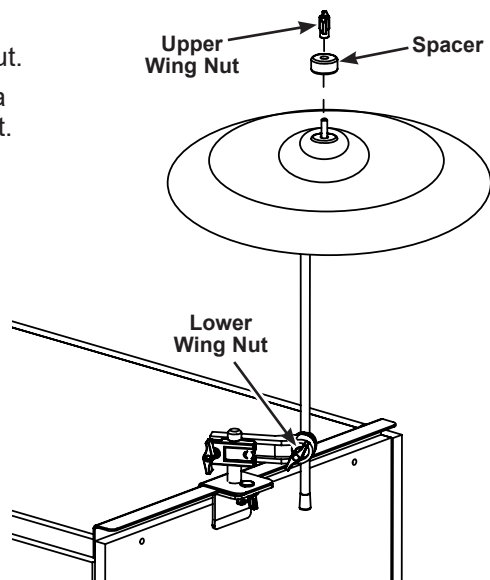

## **Cymbal Cradle Assembly**

---

1. Set the upper bracket on the percussion cabinet rail, with the flange pointing down as shown.

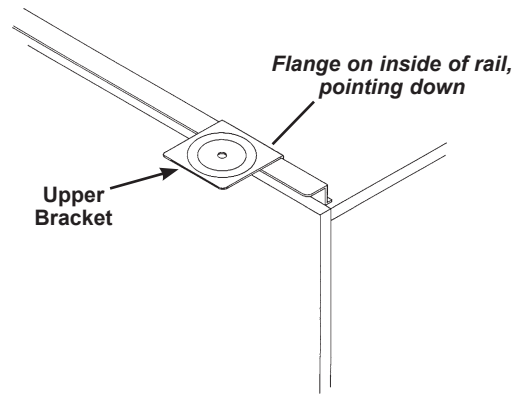

2. Insert the cradle into the hole in the upper bracket.
3. Secure the cradle loosely with the lower plate and a 5/16-8 wing nut.
4. Move the cradle along the rail to a convenient position, then lock securely with the wing nut.

